

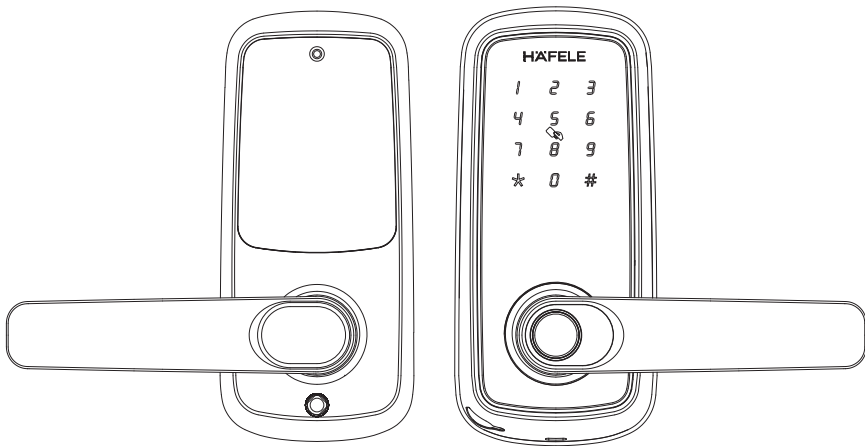

Digital door lock
Model DH2100



DH2100 Installation guide & User manual

Contents

Read before using

Product features	2
Warnings	3
Product specifications	3

Installation guide

Components.....	4
Preparing for installation.....	5
Installation steps.....	6

Lock settings

Factory default settings.....	11
Key operation.....	11
Demo mode.....	12
Add the admin data.....	12
Add the user data.....	13
Delete access right.....	14
Passage/auto locking modes.....	14
Volume control.....	14

Application settings

Bluetooth connection setting.....	15
Add the admin data via APP.....	15
Add the user data via APP.....	15
Delete the Admin/User data via APP.....	16
Create the dynamic PIN code via APP.....	16
Adjust the volume via APP.....	16
Change the system language via APP.....	16

How to use

Open and lock the door.....	17
-----------------------------	----

Service features

Type-C emergency power supply	19
Restore to factory setting.....	19

Read before using



Product features

5 WAY
OPEN

Five ways solution

Five electronic locking modes: Fingerprint, PIN code, key card, Häfele Smart Living App and emergency key.

1 2 3
4 5 6

Admin, User PIN code(6-8 digits): Maximum capacity is 100.

Admin, User card: Maximum capacity is 100.

Admin, User fingerprint: Maximum capacity is 50.



1 2 3
4 5 6

Random security coding function

A random number can be added before or after the real user PIN code but the maximum length is 16 digits. This feature will prevent the real user PIN code from being exposed.



Prevent mischief and hacking

When entering 6 times a wrong user PIN code or key card or 10 times wrong fingerprint, the lock is suspended for 1 min. After that, the lock will activate again. While the lock is suspended, the screen will flash when you are trying to use the keypad.



Alarm for battery replacement time

When battery power is too low, a warning voice will sound.

Please replace all batteries immediately.

Read before using

✓ Warnings

- * Read and understand all instructions before use.
- * If damage is caused by failure to follow this instructions, the warranty does not apply.
- * Only use alkaline batteries. It is not recommended to use special batteries such as EVOLTA, etc.
- * Do not expose the product and accessories to rain or water.
- * Do not expose the product to corrosive substances to avoid damage to the protective cover.
- * When cleaning the product, please wipe it with a soft cloth.
- * If there is a low battery alert, please replace all the batteries in time and make sure they are properly installed.

✓ Product specifications

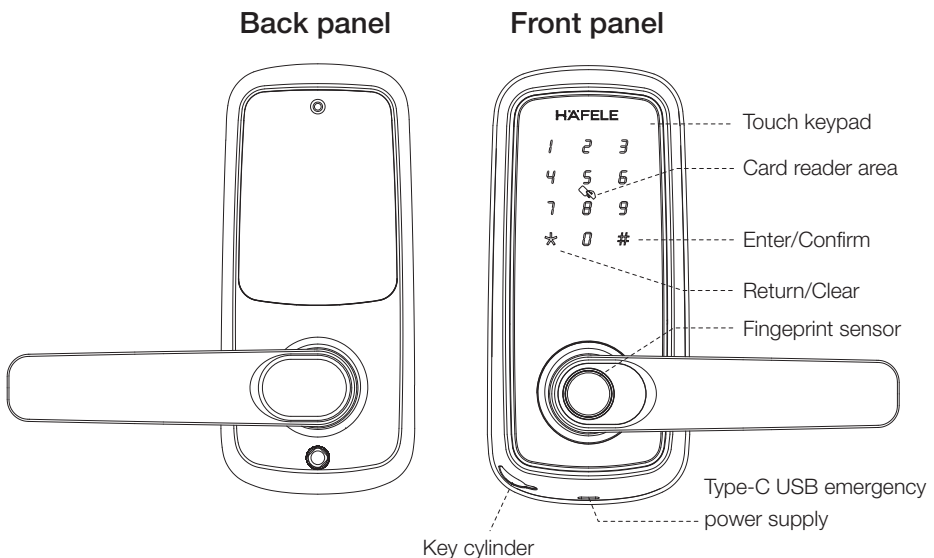

⚠ CAUTION

1. You can follow the voice guide in 2 languages (English/Chinese).
2. Initial state, any PIN code, Card or Fingerprint can open the door.
3. Admin user: Combination of PIN code, Card and Fingerprint (Setup via application).
4. Admin, User PIN code (6-8 digits): Maximum capacity is 100.
5. Admin, User card: Maximum capacity is 100.
6. Admin, User fingerprint: Maximum capacity is 50.

Installation guide



Components

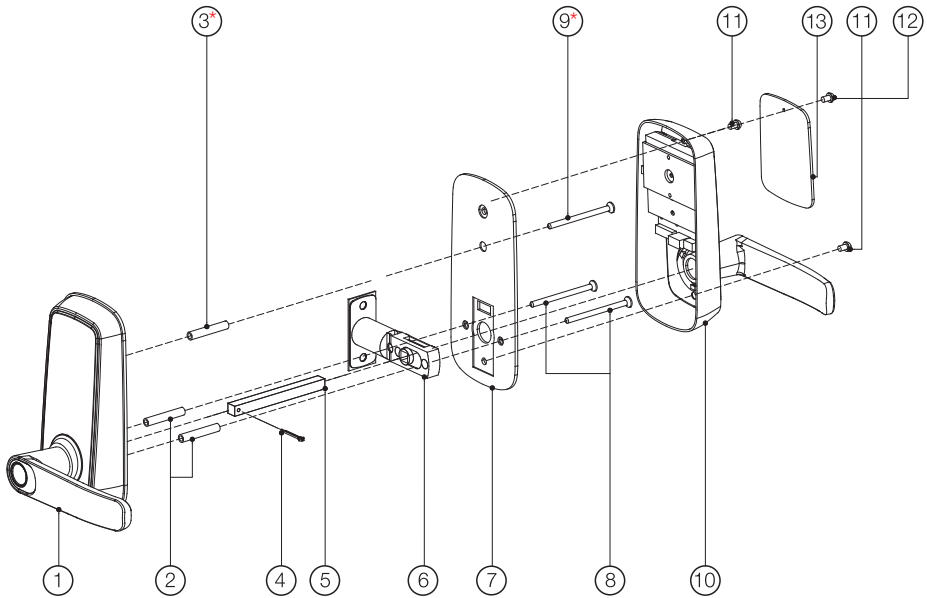

1. Front panel

2. Stud(2pcs)

3. Optional stud for
optimal fixation*

4. Split lock pin

5. Spindle

6. Latch

7. Mounting plate

8. M4 Screw(2pcs)

9. Optional screw for
optimal fixation*

10. Back panel

11. M4 x 20 mm
Screw (2pcs)

12. M3 Screw

13. Battery cover

Installation guide

✓ Preparing for installation

Check door open direction

This product fits for all door open directions Left-in / Left-out / Right-in / Right-out.

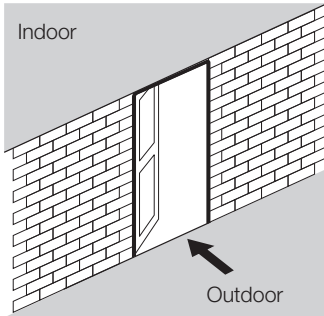

Left-in

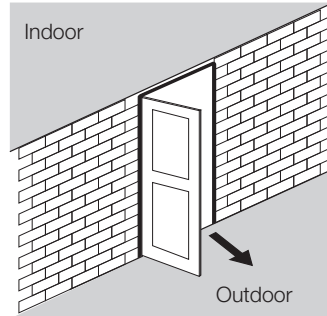

Left-out

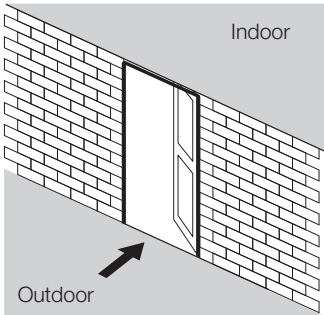

Right-in

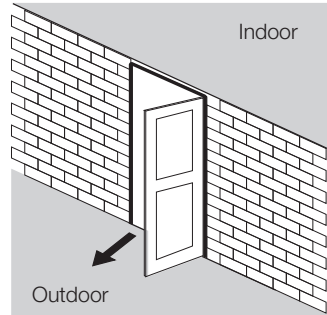

Right-out

Installation guide

✓ Preparing for installation

Adjust the backset

This latch lock can be adjusted to a backset of 60 – 70 mm by following the description below.

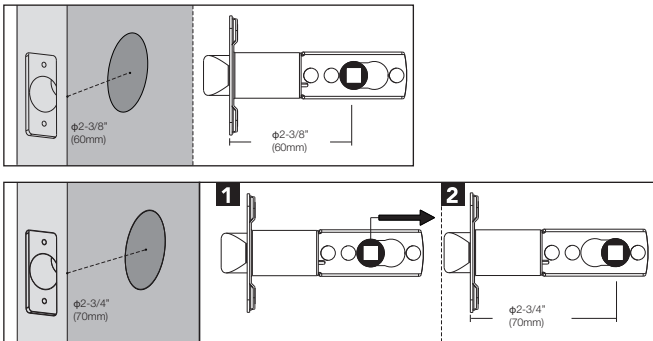

✓ Installation steps

1. Mark and drill bores using the installation template first, then fix the latch lock into the door frame.

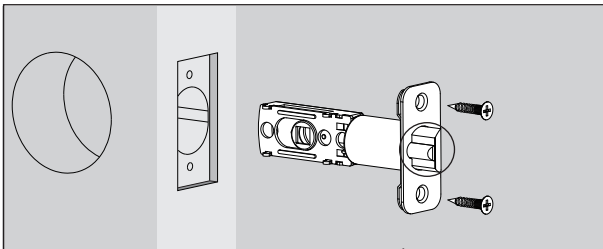

2. Install the strike plate onto door jamb.

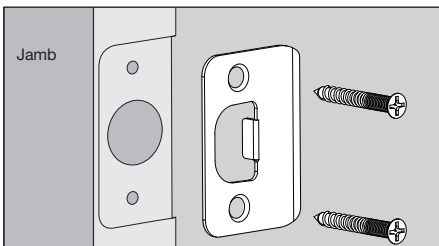

Installation guide



Installation steps

Please confirm the door opening direction

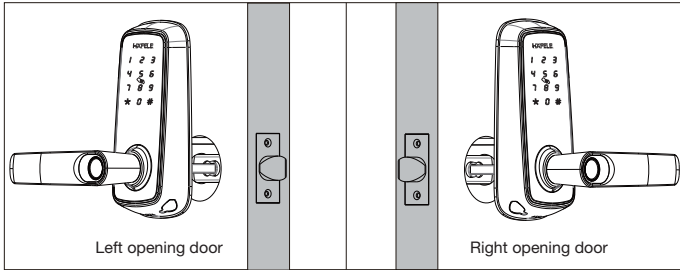

Fix Front Lever Handle

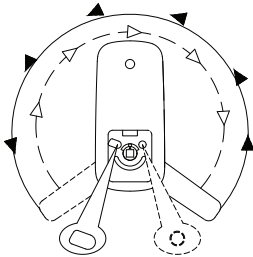

Step 1

Please confirm the door opening direction firstly, and then reverse the handle direction correspondingly by turn it 180° from upside.

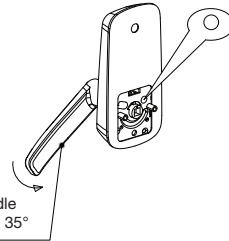

Step 2

Hold the handle downward by 35°, until the hole of positioning screw can be seen.

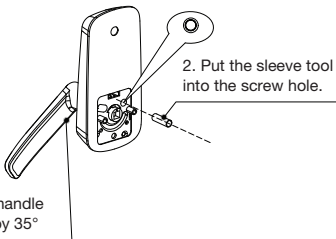

Step 3

Continually hold the handle downward by 35° and put the sleeve tool into the screw hole.

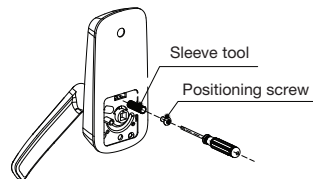

Step 4

Put the positioning screw into the sleeve tool and fix the screw tightly.

Installation guide

✓ Fix Front Lever Handle

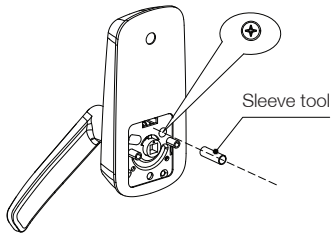

Step 5

Make sure the screw is tightened enough, and then take out the sleeve tool.

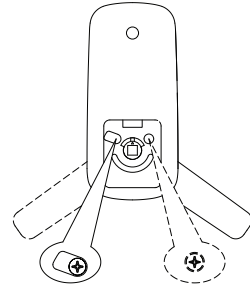

Left-hand open Right-hand open

Step 6

Test the handle whether it works smoothly.

✓ Reverse Back Lever Handle

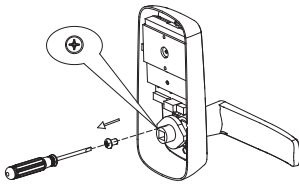

Step 1

Loose positioning screw.

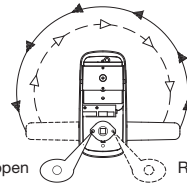

Left-hand open Right-hand open

Step 2

Turn the handle 180° from upside to reverse the handle.

Step 3

Fix the handle by positioning screw.
(Make sure the screw is tightened enough)

⚠ CAUTION

The back lever handle is pre-attached to the panel. Please confirm whether the handle direction needs to be adjusted based on the door opening direction before installation.

Installation guide

✓ Install split lock pin

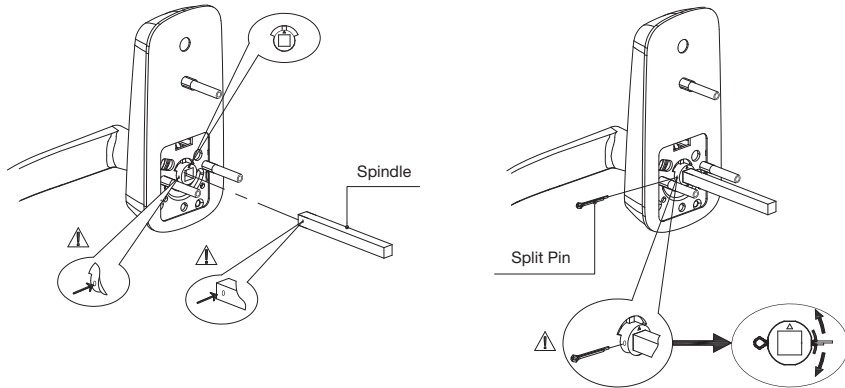

✓ Install front panel

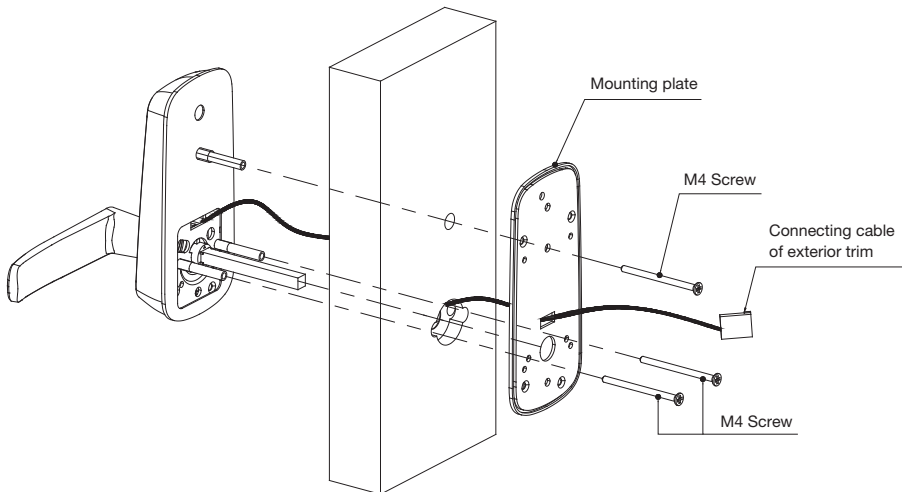

Installation guide



Install back panel

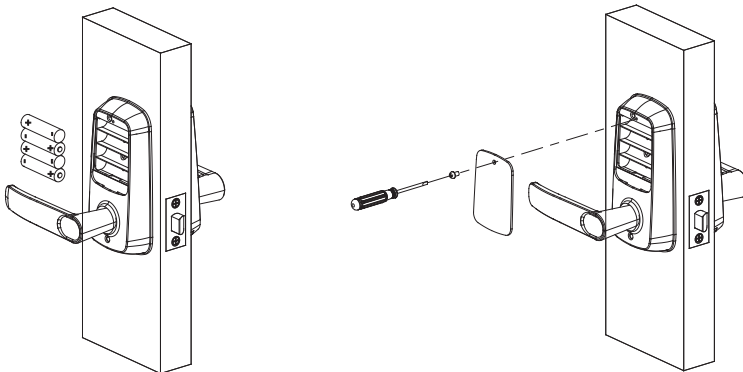
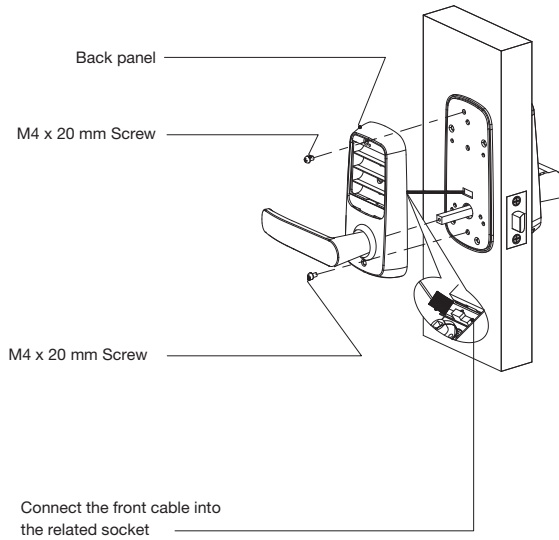









Lock settings

✓ Factory default settings

Settings	Factory defaults
Bluetooth	Enabled
Speaker	Enabled
Wrong code entry limit	6 times
Shut down time	1 minute
Voice guide language	English

*Important: First step is to set admin PIN code.

✓ Key operation

-  **IN** Input the key by pressing * then #
-  **AM** Input administrator/master right
-  **Card** Enter card
-  Enter fingerprint
-  ***** Star key, return to previous menu/clear data
-  **#** Hash key, enter/confirm
-  Touch the screen to activate the lock
-  Voice prompt

Lock settings

✓ Demo mode

When the lock is new or restored to factory setting, any fingerprint, keycard or PIN code can open the door.

✓ Add the admin data

Admin PIN code



- ✓ Successful registration. Please register administrator (user).
- ✗ Inconsistency password, register fail.

⚠ CAUTION

1. PIN code register is not complete when you hear the voice prompt “Inconsistency password, register failed”. Please enter the password again.
2. Administrator data is for entering the setting menu and can also be used for unlocking the door.
3. The lock setting will allow to add only 1 set of Admin PIN code, If you would like to add more administrator data please perform this action via application on the smart phone. It will allow you to add the Fingerprints / Cards or PIN codes.

Lock settings

✓ Add the user data

User PIN code



- ✓ Successful registration. Please register administrator (user).
- ✗ Inconsistency password, register fail.

User key card

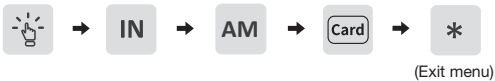

User fingerprint

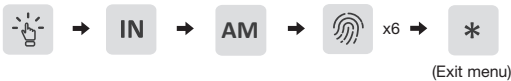

⚠ CAUTION

1. Make sure your fingers are clean and dry before using the fingerprint reader. Dirt, oil, and moisture can interfere with recognition.
2. The PIN code register is not complete when you hear the voice prompt "Inconsistency password, register failed" please enter the password again.
3. User data will only be used for unlocking the door and cannot access the settings menu.

✓ Correct way to enroll a fingerprint

1. Place your finger on the sensor and lift it when prompted by the sound guide.
2. Repeat the enrollment 6 times, slightly adjusting the fingerprint angle each time to ensure complete coverage of the five fingerprint areas (as shown in the diagram).
3. After finishing, press "*" to exit.

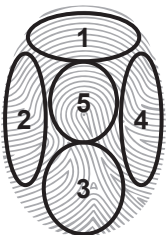

⚠ CAUTION

1. Use the center of your finger for enrollment, not the fingertip.
2. The same fingerprint should be scanned from multiple angles to ensure complete coverage of the five fingerprint areas (as shown in the left figure), which will improve fingerprint recognition accuracy.
3. For users with shallow fingerprints, it is recommended to enroll the same finger multiple times to improve recognition accuracy.
4. Keep your fingers clean and avoid enrolling when they are too dry or too wet.

Lock settings

✓ Delete access right

You cannot delete access right from the lock directly. Please use Hafele Smart living App for deleting. Please see how to operate on page 15.

✓ Passage/auto locking modes

After unlocking by PIN code, card or fingerprint, number 2 and number 8 will light up for 3 seconds. If you press number 2 and number 8 respectively, the lock will be on passage mode.

To back to auto locking mode, please verify enrolled PIN code, card, fingerprint then the lock will back to auto locking mode again.

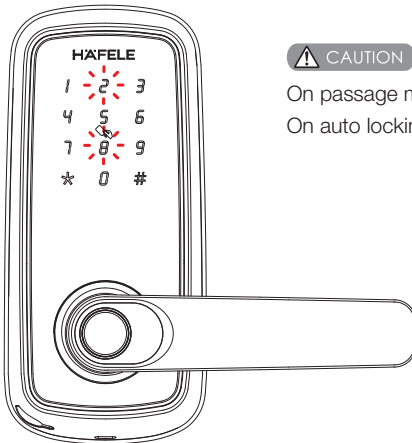

⚠ CAUTION

On passage mode, any users can open the door.

On auto locking mode, only grant user can open the door.

✓ Volume control

Volume of voice prompt can be adjusted or mute. This function does not affect to voice prompt of low battery warning. You cannot use this function from the lock directly.

Please use Hafele Smart living App to adjust the volume. Please see how to operate on page 16.

Application settings

✓ Bluetooth connection setting

Please carefully do the following steps to connect the lock with the Hafele Smart Living App.

1. Download Application “Hafele Smart Living” from the App Store and Play Store.



2. Turn on the phone's Bluetooth and open the APP.
3. Sign up App's account by email or log in if you already have an account.
4. Click “Add device”, after that APP will show the available lock on the top with the “Add” icon.
If lock is not in the demo mode(Factory setting), please access to menu setting to make the APP able to pair the lock.
5. Click “Add”, after the Bluetooth connection is established, click “Done” to finish the pairing process.

✓ Add the admin data via APP

1. Turn on the phone's Bluetooth and open the APP.
2. Click “Member Management”. Then choose the **admin account**.
3. Choose the access type to be added (Fingerprint, PIN code, Card) then do the following step that show on the phone's screen.

⚠ CAUTION

1. You must be within range of the lock's Bluetooth connection.
2. The admin added in this operation will be the permanent type.
3. Administrator data is for entering the setting menu and can also be used for unlocking the door.

✓ Add the user data via APP

1. Turn on the phone's Bluetooth and open the APP.
2. Click “Member Management”. Then choose the **user account**.
3. Choose the access type to be added (Fingerprint, PIN code, Card) then do the following step that show on the phone's screen.

⚠ CAUTION

1. You must be within range of the lock's Bluetooth connection.
2. The user added in this operation will be the permanent type.

Application settings

✓ Delete the Admin / User data via APP

1. Turn on the phone's Bluetooth and open the APP.
2. Click the "Member Management" icon , then choose the user account.
3. Choose the access type to be deleted (Fingerprint, PIN code, Card), then click "Delete".

⚠ CAUTION

You must be within range of the lock's Bluetooth connection.

✓ Create the dynamic PIN code via APP

1. Open the APP.
2. Click the "Temporary Code" icon.
3. Click the "Get Code" icon.
4. The app will generate the Password and you can send it to another person.

⚠ CAUTION

1. You can create the dynamic PIN code from anywhere.
2. The dynamic PIN code is valid for 5 minutes only.

✓ Adjust the volume via APP

1. Open the APP.
2. Click "More" icon.
3. Click "Lock Volume" menu.
4. Select the volume level (High, Normal, Low, Mute)
5. Then click "OK"

⚠ CAUTION

You must be within range of the lock's Bluetooth connection.

✓ Change the system language via APP

1. Open the APP.
2. Click "More" icon.
3. Click "Lock Language" menu.
4. Select the language (Chinese, English, Thai)
5. Then click "Confirm"

⚠ CAUTION

You must be within range of the lock's Bluetooth connection.

How to use

✓ Open and lock the door

Open the door from outside

PIN code

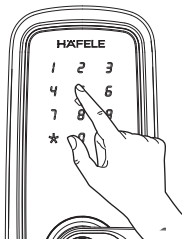

1. Touch keypad by palm to lighten keypad.
2. Enter the enrolled PIN code with end of [#]. Voice prompt "The lock is opened".
3. Press down handle to open the door.

Key card

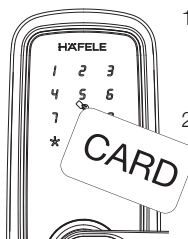

1. Enter the enrolled card on the card icon area. Voice prompt "The lock is opened".
2. Press down handle to open the door.

Random security coding function

The random number can be added before or after the real user PIN code but the maximum length is 16 digits. This feature will prevent the real user PIN code from being exposed.

Fingerprint

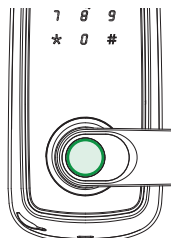

1. Enter the enrolled finger on the fingerprint sensor area. Voice prompt "The lock is opened".
2. Press down handle to open the door.

⚠ CAUTION

1. When you hear voice prompt "Verification failed. Please try again.", you do not have access right and cannot open the door.
2. Make sure your fingers are clean and dry before using the fingerprint reader. Dirt, oil, and moisture can interfere with recognition.

How to use

✓ Open and lock the door

Mechanical key

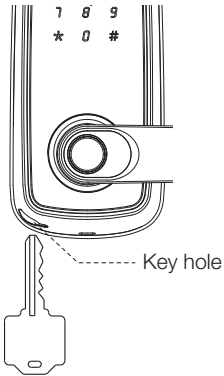

The mechanical key can be used if the door lock has become unresponsive such as battery is fully discharged.

Open the door as below steps.

1. Open the cover of key hole.
2. Insert the mechanical key into the key hole and turn the key.
3. Open the door by pressing down the door handle.

Open the door from inside

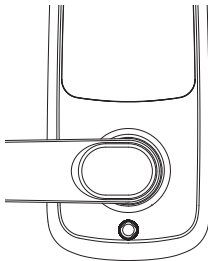

The door can be unlocked and opened from inside anytime by pressing down the door handle.

Service features

✓ Type-C emergency power supply

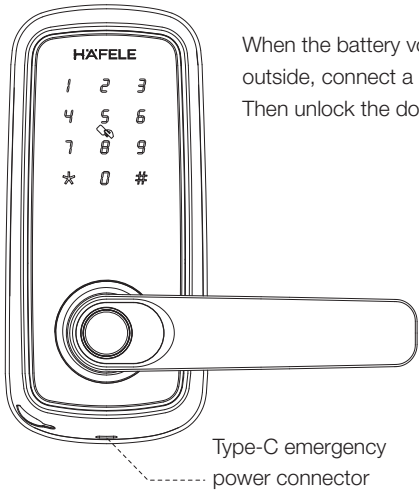

When the battery voltage is too low and cannot be opened from outside, connect a 5V power supply via Type-C USB port at the front. Then unlock the door and replace all batteries immediately.

✓ Restore to factory setting

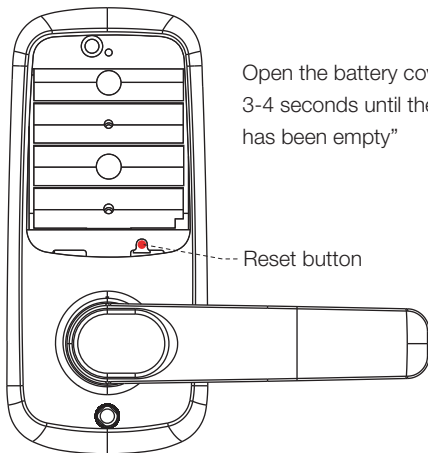

Open the battery cover then press the reset button by paper clip for 3-4 seconds until the lock voice prompts "Initializing system, system has been empty"

⚠ CAUTION

After restore to factory setting, all administrator/user data and settings will be deleted.